

# HIGH SCHOOL Math TEKS FOCUS

## Objective Seven

**8.7A**

*Draw solids from different perspectives*

50 The drawings show the top view and the front view of a solid figure built with cubes.

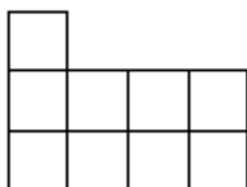

Top View

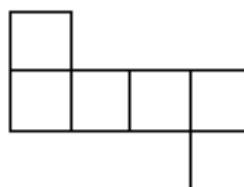

Front View

Which drawing shows a 3-dimensional view of the solid figure represented above?

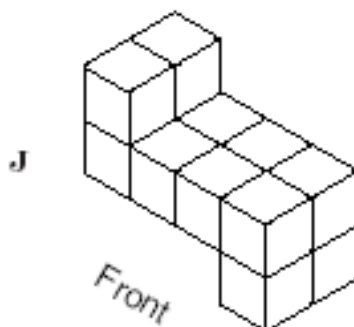
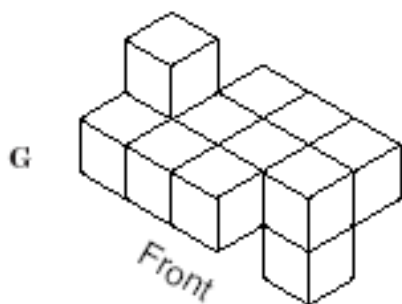
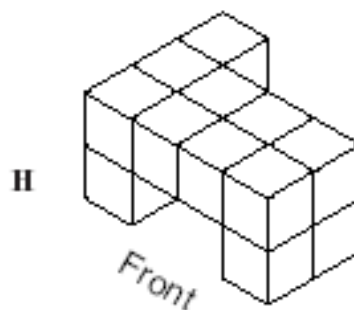
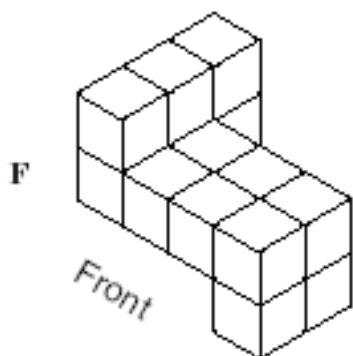

8.7A 8th Grade 2003

High School Math TEKS Focus  
Objective Seven

- 44 The picture below shows a toolbox with a black handle.

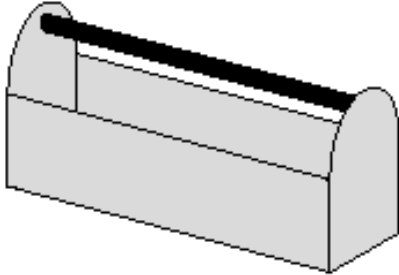

Which drawing best represents a top view of the toolbox?

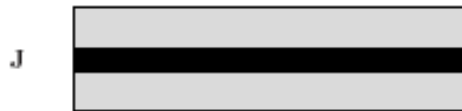

8.7A 8th Grade 2004

High School Math TEKS Focus  
Objective Seven

12 Match the three views of this solid to its 3-dimensional sketch.

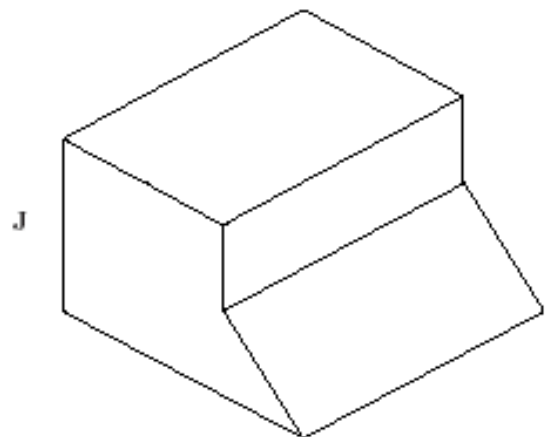
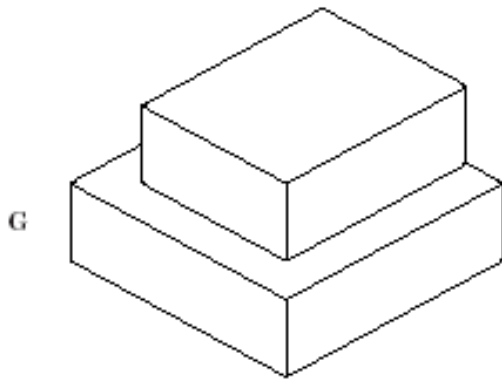
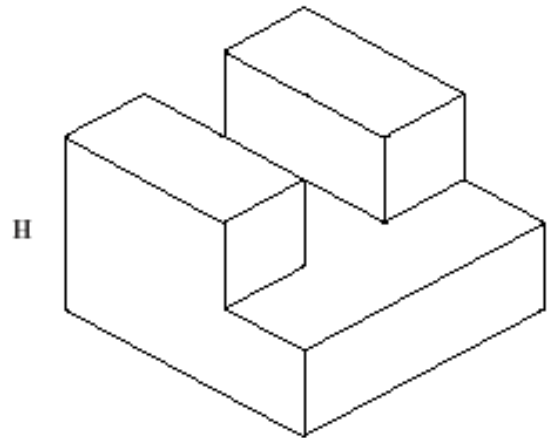
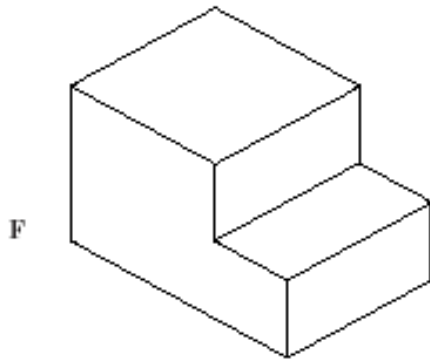

8.7A 9th Grade 2003

## HIGH SCHOOL Math TEKS Focus Objective Seven

4 The drawing shows a 3-dimensional solid.

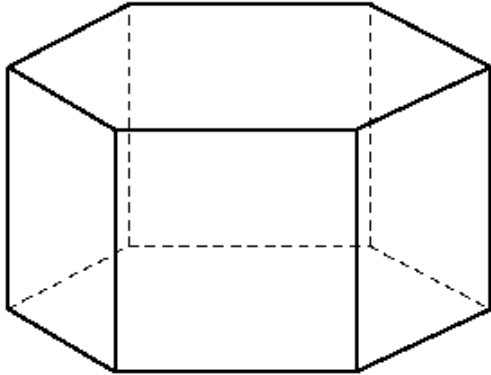

Which best represents the shape of the solid when viewed from the top?

- F** Pentagon
- G** Hexagon
- H** Heptagon
- J** Octagon

8.7A 9th Grade 2004

3 The drawing shows a view of a building.

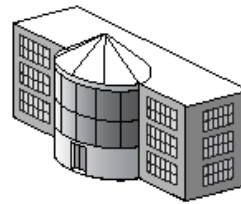

Which drawing best represents the top view of this building?

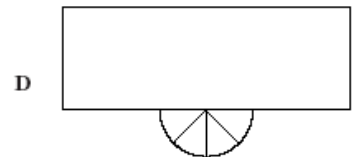
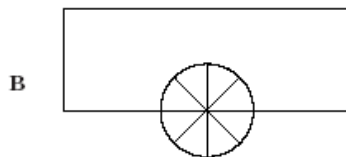
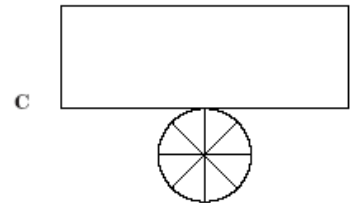
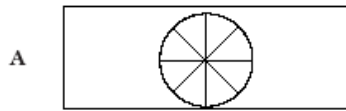

8.7A 10th Grade 2003

## HIGH SCHOOL Math TEKS Focus Objective Seven

- 56 The drawing shows the top view of a structure built with cubes as well as the number of cubes in each column of the structure.

	3	4	Right
1	3	2	
Front			

Which 3-dimensional view represents the same structure?

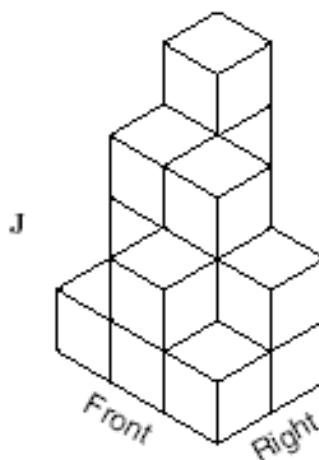
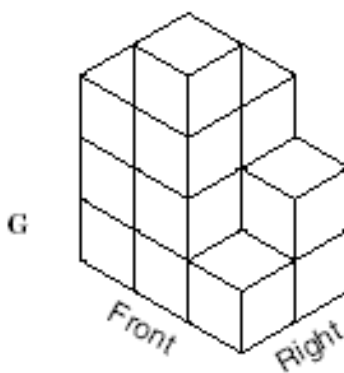
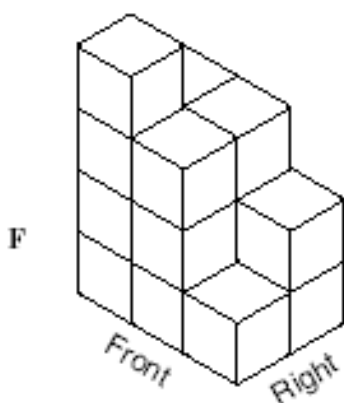

8.7A 10th Grade 2004

High School Math TEKS Focus  
Objective Seven

38 A toy truck wheel is shown below.

**8.7B**

*Use geometric concepts and properties to solve problems in fields such as art and architecture*

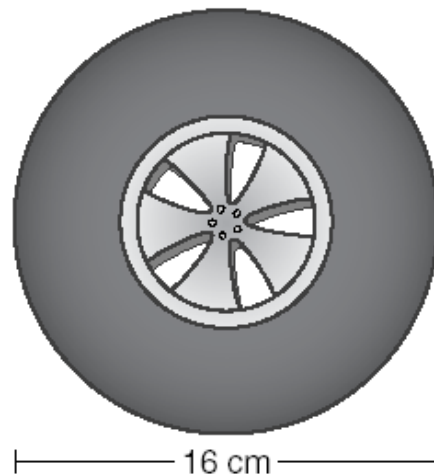

13 A bicycle wheel travels about 82 inches in 1 full rotation. What is the diameter of the wheel, to the nearest inch?

- A 5 in.
- B 10 in.
- C 13 in.
- D 26 in.

8.7B 8th Grade 2003

5 An architect designed a rectangular room with an area of 925 square feet.

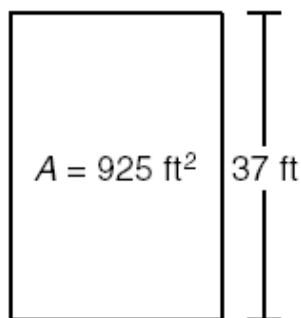

What is the width of the room if the length is 37 feet?

- A 25 ft
- B 74 ft
- C 425.5 ft
- D 462.5 ft

8.7B 8th Grade 2004

Which is closest to the distance traveled during 2 full rotations of the toy truck wheel?

- F 50.2 centimeters
- G 100.5 centimeters
- H 200.9 centimeters
- J 401.9 centimeters

8.7B 8th Grade 2004

21 A lawn is shaped like a parallelogram with a base of 32 feet and a height of 15 feet. Covering the lawn with grass will cost \$2.60 per square foot. How much money will it cost to cover the lawn with grass?

Record your answer and fill in the bubbles on your answer document. Be sure to use the correct place value.

8.7B 9th Grade 2003

**HIGH SCHOOL Math TEKS FOCUS**  
**Objective Seven**

**31** A 12- by 16-foot rectangular floor will be covered by square tiles that measure 2 feet on each side. If the tiles are not cut, how many of them will be needed to cover the floor?

- A** 192
- B** 96
- C** 48
- D** 14

8.7B 9th Grade 2003

**30** An artist made a drawing of a house with a tree next to it. The drawing is  $\frac{1}{18}$  the size of the actual house and tree. The tallest point of the house is 12 feet 8 inches, and the tree is 27 feet tall. How many inches tall is the tree in the drawing?

- F** 8.4 in.
- G** 18 in.
- H** 23.4 in.
- J** 486 in.

8.7B 9th Grade 2004

**49** Ms. Hill wants to carpet her rectangular living room, which measures 14 feet by 11 feet. If the carpet she wants to purchase costs \$1.50 per square foot, including tax, how much will it cost to carpet her living room?

- A** \$50
- B** \$75
- C** \$154
- D** \$231

8.7B 9th Grade 2004

**12** A blueprint of a house plan uses a scale in which  $\frac{1}{4}$  inch equals 1 foot. If the length of one side of the house is 65 feet, how many inches will the length be on the blueprint?

**F** 4 in.

**G**  $16\frac{1}{4}$  in.

**H**  $65\frac{1}{4}$  in.

**J** 260 in.

8.7B 10th Grade 2003

# High School Math TEKS Focus

## Objective Seven

- 21 A regular hexagon is drawn in a circle as a design on a window. Opposite vertices are connected by line segments.

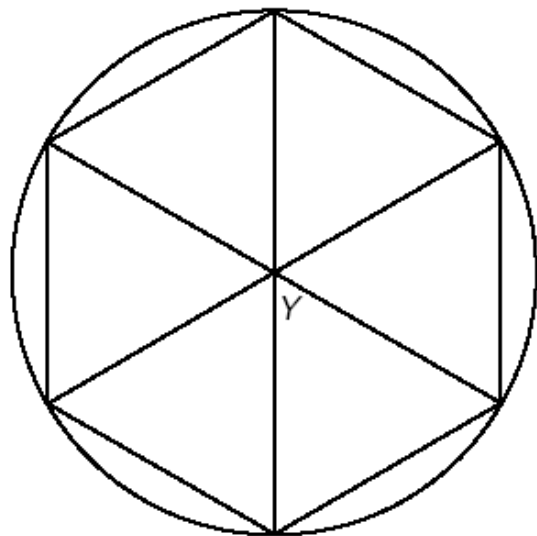

What is the measure of angle Y in degrees?

Record your answer and fill in the bubbles on your answer document. Be sure to use the correct place value.

8.7B 10th Grade 2003

- 9 The blueprint dimensions for a newly constructed house are proportional to the house's actual dimensions. On the blueprints the house's foundation measures 75 centimeters long by 40 centimeters wide. If the house's foundation measures 15 meters long, what is the foundation's actual width?

- A 8 m
- B 28.1 m
- C 50 m
- D 200 m

8.7B 10th Grade 2004

- 41 Near the downtown area of a city, there is a vacant triangular plot of land with sides that measure 22 feet, 27 feet, and 17 feet. If the city council decides to plant an oak tree in the corner with the smallest angle, where should the tree be planted?

- A In the corner opposite the side that is 17 feet
- B In the corner opposite the side that is 22 feet
- C In the corner opposite the side that is 27 feet
- D In the center of the triangular plot

8.7B 10th Grade 2004

- 50 Mr. Harrison wants to calculate the cost of buying a carpet to cover his rectangular living room floor. He knows the cost per square foot of carpet, and he knows the length, width, and height of the living room. Which geometric formula should Mr. Harrison use to determine the cost of the carpet he needs?

F  $c^2 = a^2 + b^2$

G  $V = Bh$

H  $A = lw$

J  $P = 2l + 2w$

8.7B 10th Grade 2004

# HIGH SCHOOL Math TEKS FOCUS

## Objective Seven

### 8.7C

*Use pictures or models to demonstrate the Pythagorean Theorem*

- 37 Which figure best represents a triangle with sides  $a$ ,  $b$ , and  $c$  in which the relationship  $a^2 + b^2 = c^2$  is always true?

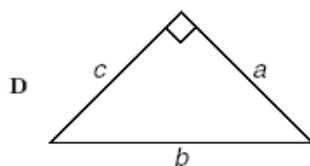
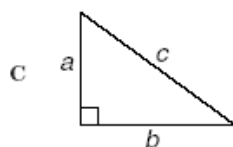
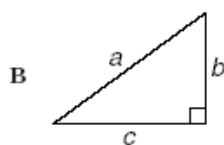
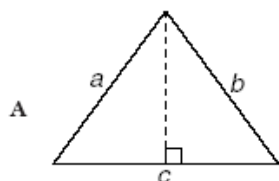

8.7C 8th Grade 2003

- 33 The drawing below shows 3 square parking lots that enclose a grassy area shaped like a right triangle.

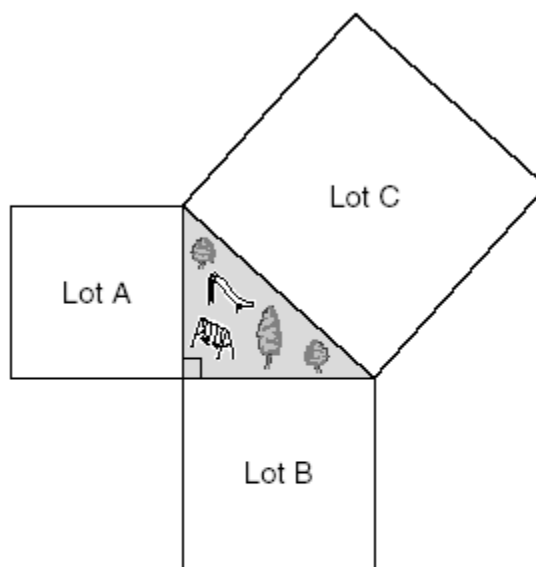

If Lot A's perimeter is 300 yards and Lot B's perimeter is 400 yards, what is the perimeter of Lot C?

- A 500 yd
- B 700 yd
- C 1400 yd
- D 2000 yd

8.7C 9th Grade 2004

# HIGH SCHOOL MATH TEKS FOCUS Objective Seven

14 What is the area of the largest square in the diagram?

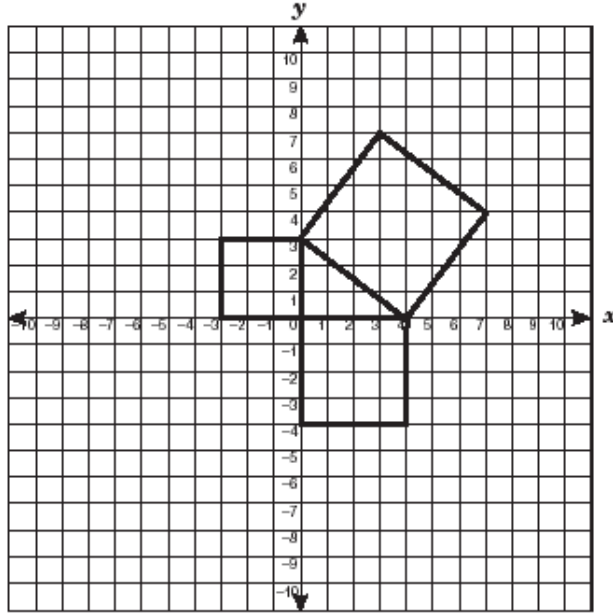

- F 5 units<sup>2</sup>
- G 9 units<sup>2</sup>
- H 16 units<sup>2</sup>
- J 25 units<sup>2</sup>

8.7C 9th Grade 2003

22 Line segment  $d$  is a diagonal in each polygon shown below. Which drawing shows enough information to find the length of line segment  $d$ ?

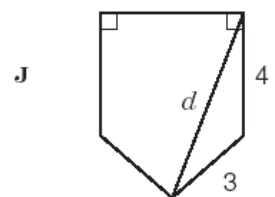
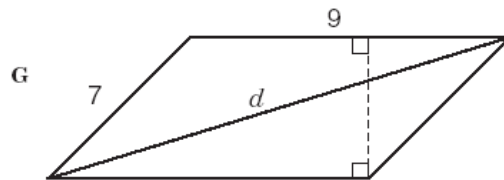
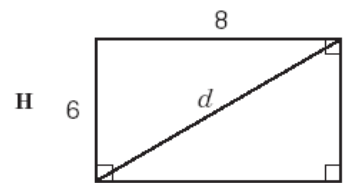
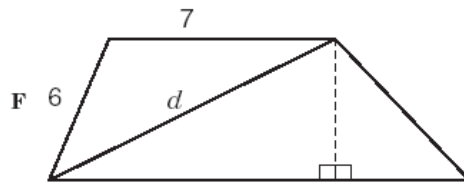

8.7C 8th Grade 2004

## HIGH SCHOOL MATH TEKS FOCUS Objective Seven

- 13 The sides of squares can be used to form triangles. The areas of the squares that form right triangles have a special relationship.

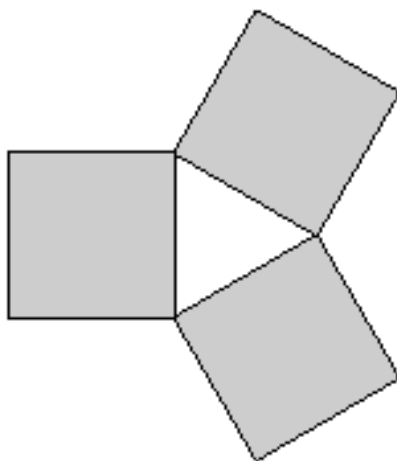

Using the dimensions of the squares shown below, determine which set of squares will form a right triangle.

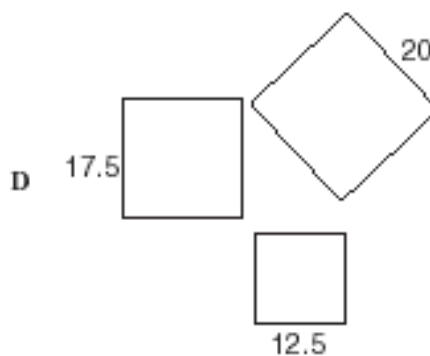
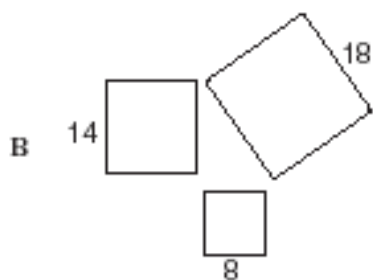
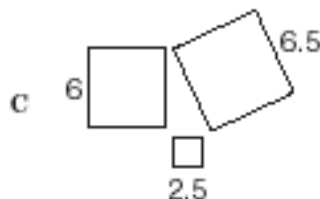
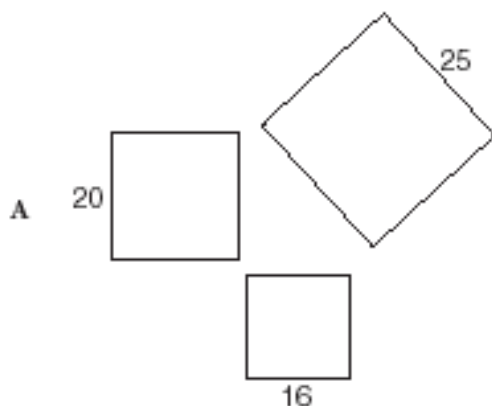

8.7C 10th Grade 2003

# High School Math TEKS Focus Objective Seven

56 Use the Pythagorean theorem to find the figure that is a right triangle.

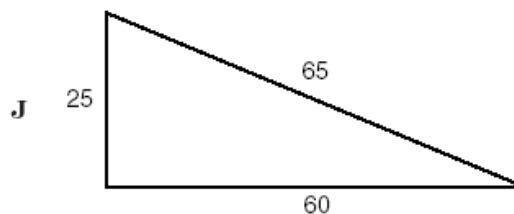
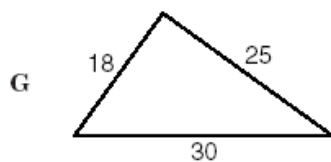
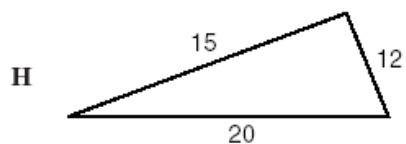
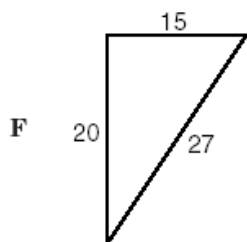

8.7C 10th Grade 2003

36 Look at the right triangle shown below. Which of the following could be the triangle's dimensions?

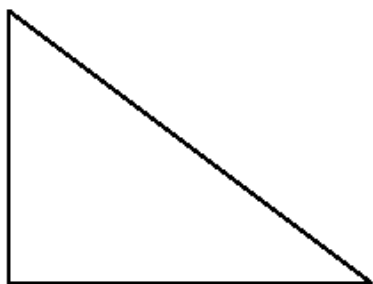

**F** 12, 16.8, 18.2

**G** 5.4, 10.6, 16

**H** 1.2, 1.6, 2

**J** 8, 10, 12.5

8.7C 10th Grade 2004

High School Math TEKS Focus  
Objective Seven

Geometry (d1B)

Use nets to represent and construct three-dimensional objects

- 1 The net below shows the surface of a 3-dimensional figure.

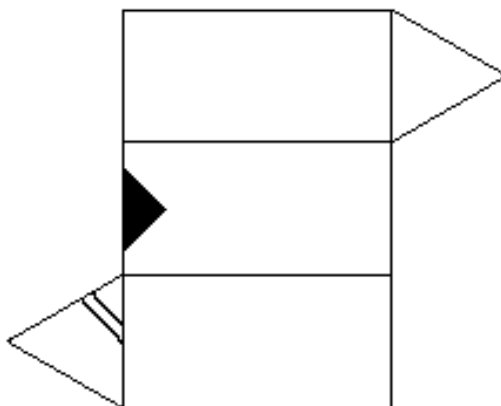

Which 3-dimensional figure does this net represent?

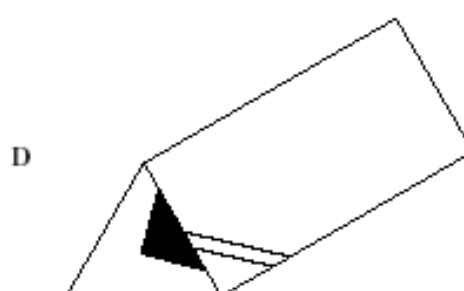
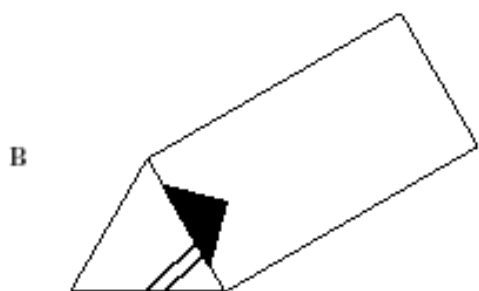
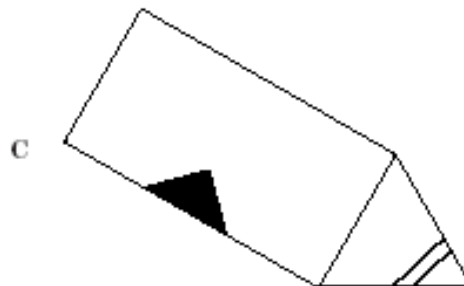
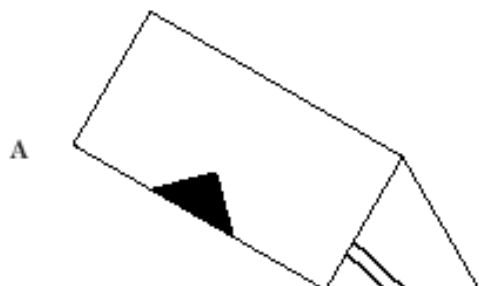

11th Grade 2003

# HIGH SCHOOL Math TEKS FOCUS

## Objective Seven

38 Which of the following is a true statement about the net of the cube shown?

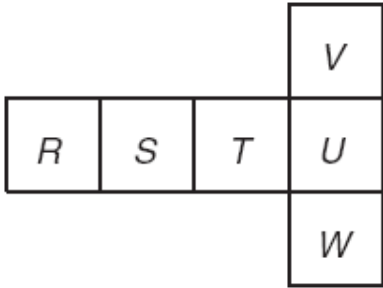

- F** Faces *R* and *S* are parallel.
- G** Faces *R* and *U* are parallel.
- H** Faces *S* and *U* are perpendicular.
- J** Faces *T* and *U* are perpendicular.

11th Grade 2004

### Geometry (d1C)

*Use top, front, side, and corner views of three-dimensional objects to create accurate and complete representations and solve problems*

15 Which of the following best represents the front view of the solid shown below?

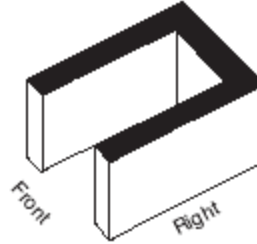

11th Grade 2004

High School Math TEKS Focus  
Objective Seven

44 What is the volume of a 3-dimensional object with the dimensions shown in the 3 views below?

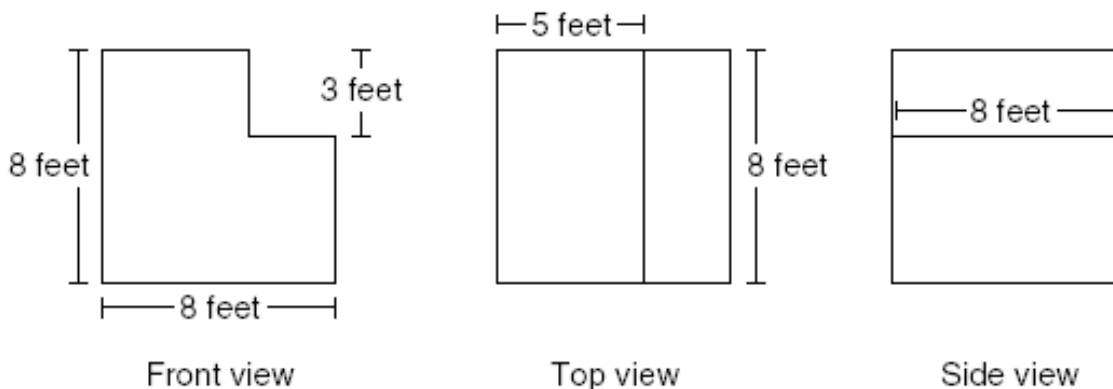

- F** 120 cu ft
- G** 440 cu ft
- H** 512 cu ft
- J** 960 cu ft

11th Grade 2003

# High School Math TEKS Focus Objective Seven

## Geometry (d2A)

Use one- and two-dimensional coordinate systems to represent points, line segments, and figures

- 58 Which of the following is the correct name for figure  $ABCD$ , with vertices  $A(4, 6)$ ,  $B(8, 7)$ ,  $C(7, 3)$ , and  $D(3, 2)$ ?

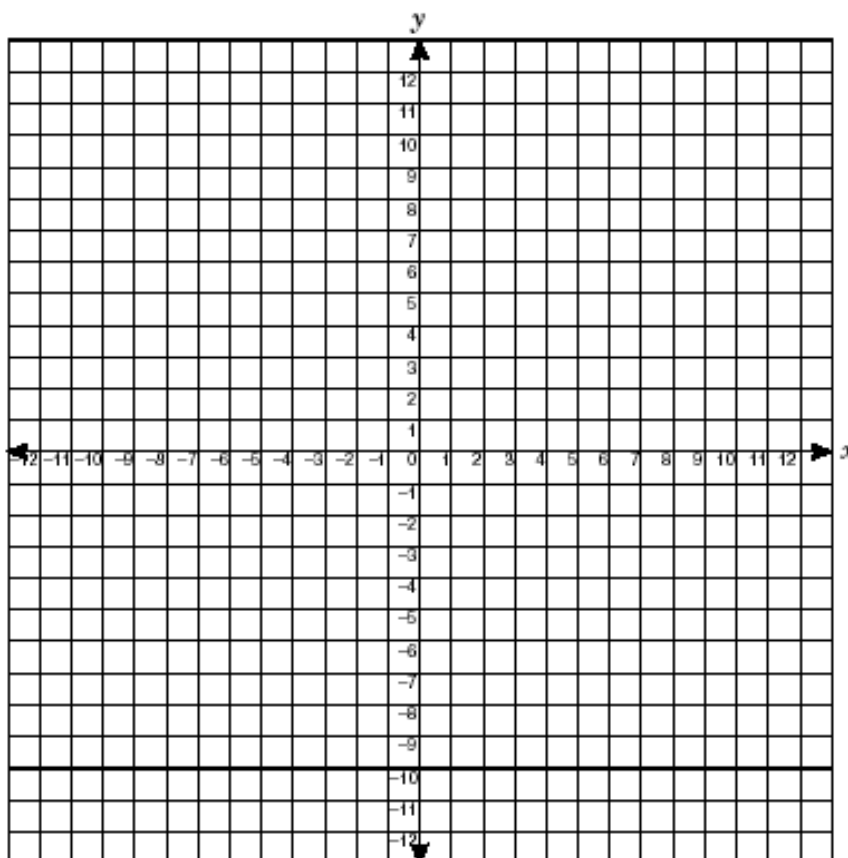

- F Rectangle
- G Rhombus
- H Trapezoid
- J Square

11th Grade 2003

High School Math TEKS Focus  
Objective Seven

50 A hexagon is graphed on the coordinate grid.

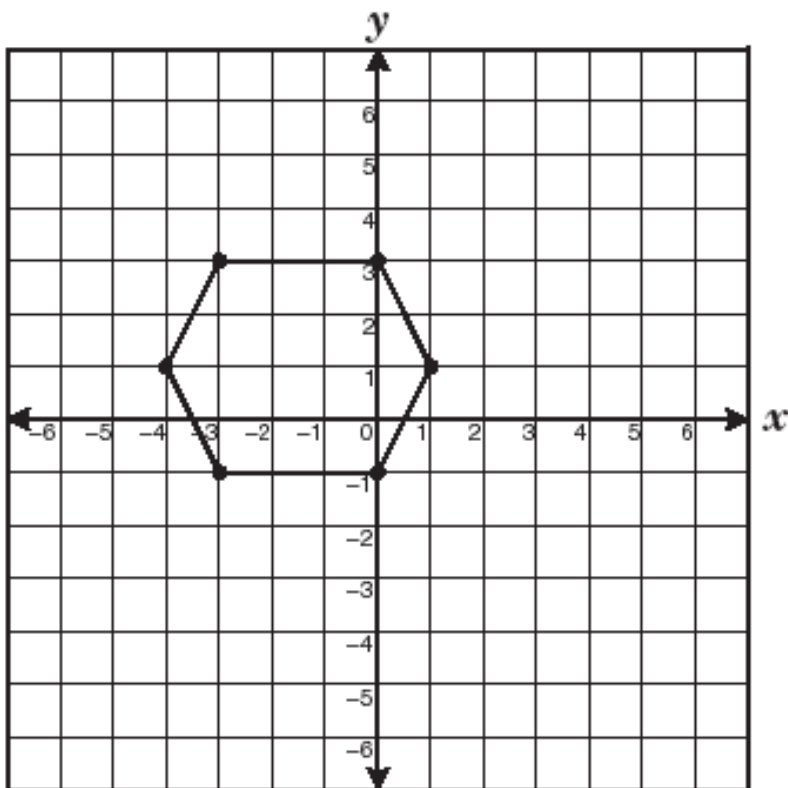

Which two coordinate points lie on the same line of symmetry on this hexagon?

**F**  $(-3, -1)$  and  $(0, 3)$

**G**  $(-1, 3)$  and  $(-1, -1)$

**H**  $(0, 3)$  and  $(0, -1)$

**J**  $(-4, 1)$  and  $(1, 1)$

11th Grade 2004

# High School Math TEKS Focus Objective Seven

## Geometry (d2B)

Use slopes and equations of lines to investigate geometric relationships, including parallel lines, perpendicular lines, and special segments of triangles and other polygons

6 Which graph best represents a line parallel to the line with the equation  $y = 3x + 4$ ?

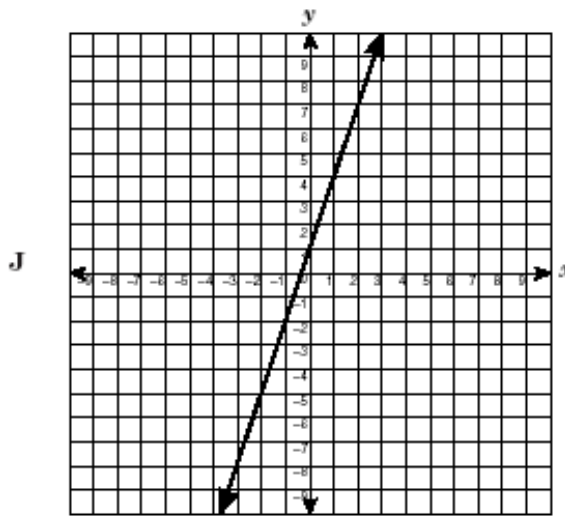
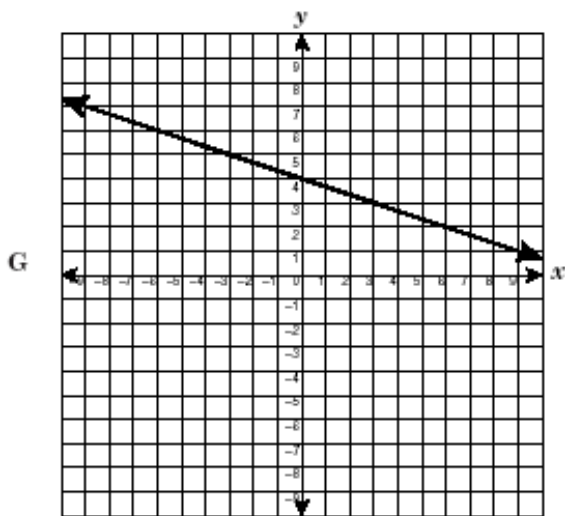
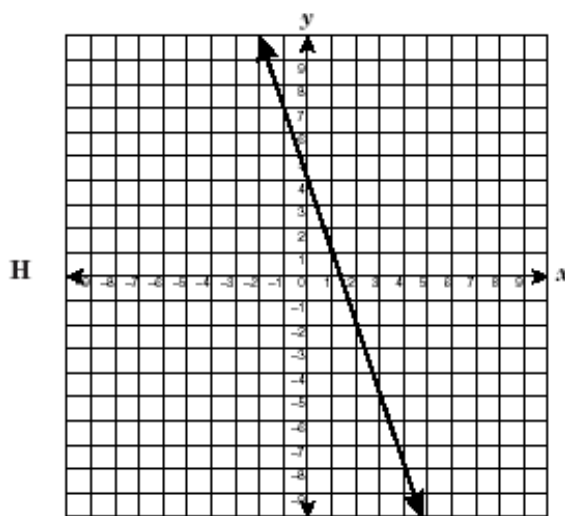
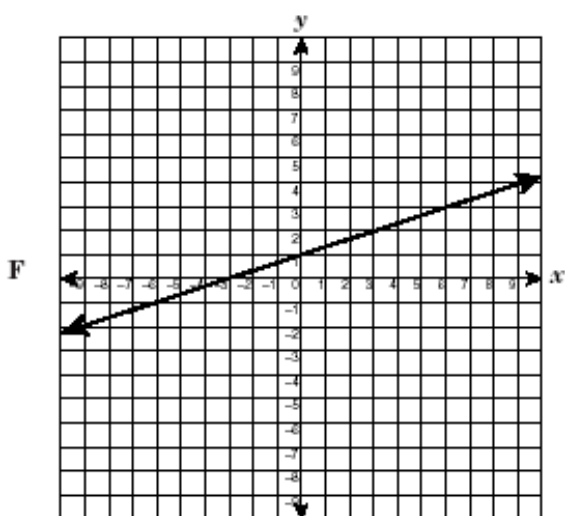

11th Grade 2003

# HIGH SCHOOL Math TEKS FOCUS

## Objective Seven

36 Which graph best represents the line passing through the point  $(0, 4)$  and perpendicular to  $y = -\frac{1}{2}x$ ?

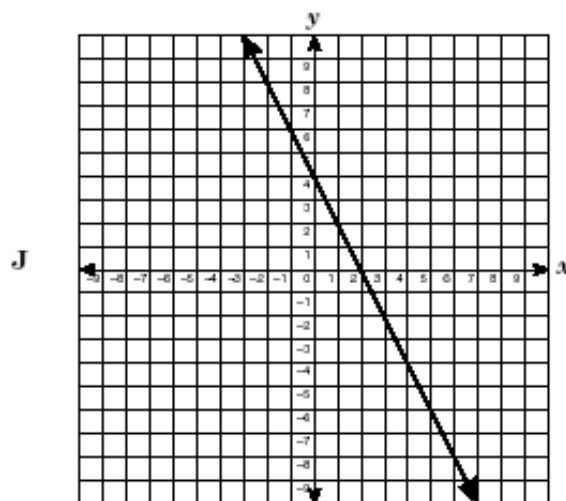
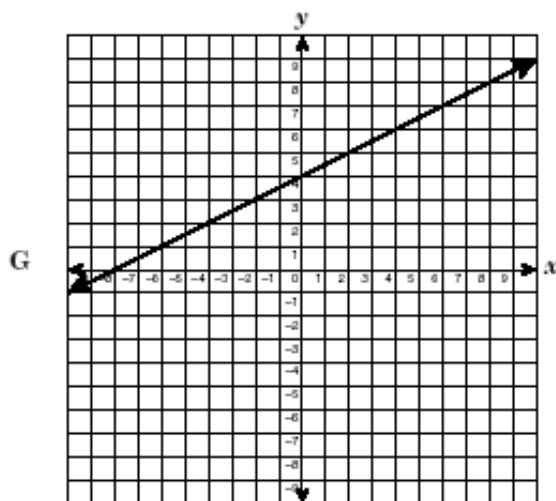
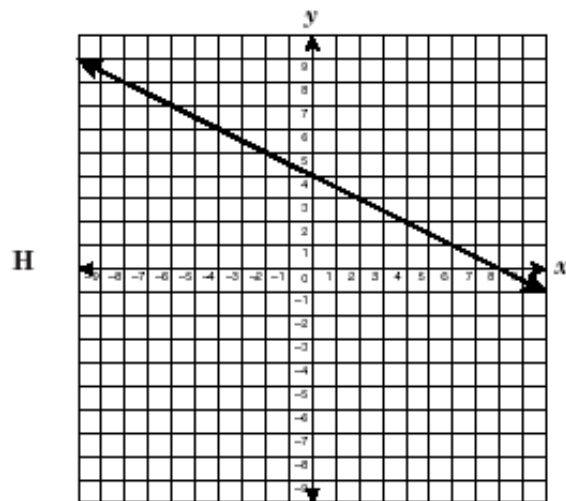
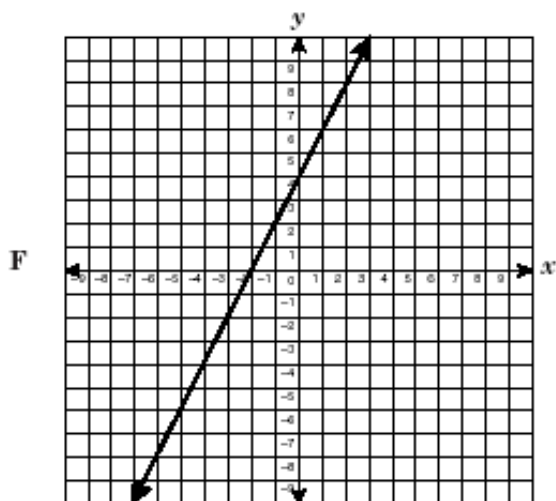

11th Grade 2003

**HIGH SCHOOL Math TEKS FOCUS**  
**Objective Seven**

- 16 Which of the following best describes the graph of the equations below?

$$2y = 3x + 2$$

$$4y = 6x + 1$$

- F The lines have the same  $y$ -intercept.
- G The lines have the same  $x$ -intercept.
- H The lines are perpendicular.
- J The lines are parallel.

11th Grade 2004

- 57 Line  $q$  is shown below.

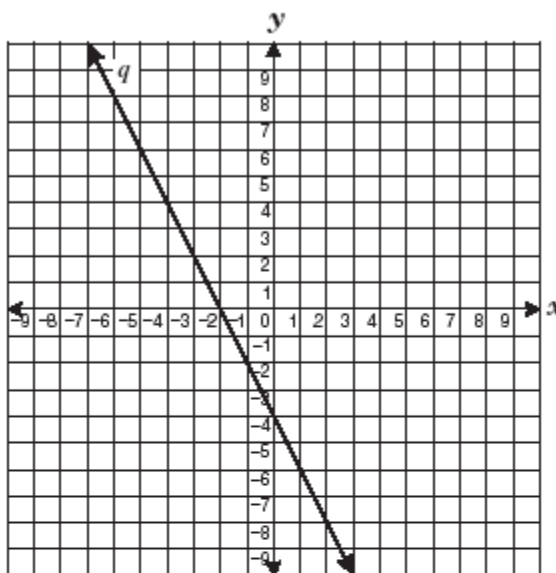

Which equation best represents a line parallel to line  $q$ ?

A  $y = -\frac{1}{2}x + 4$

B  $y = \frac{1}{2}x - 3$

C  $y = 2x - 5$

D  $y = -2x + 1$

11th Grade 2004

High School Math TEKS Focus  
Objective Seven

Geometry (d2C)

Develop and use formulas, including distance and midpoint

- 19 A coordinate grid is placed over a map. City A is located at  $(-3, 2)$ , and City B is located at  $(4, 8)$ . If City C is at the midpoint between City A and City B, which is closest to the distance in coordinate units from City A to City C?

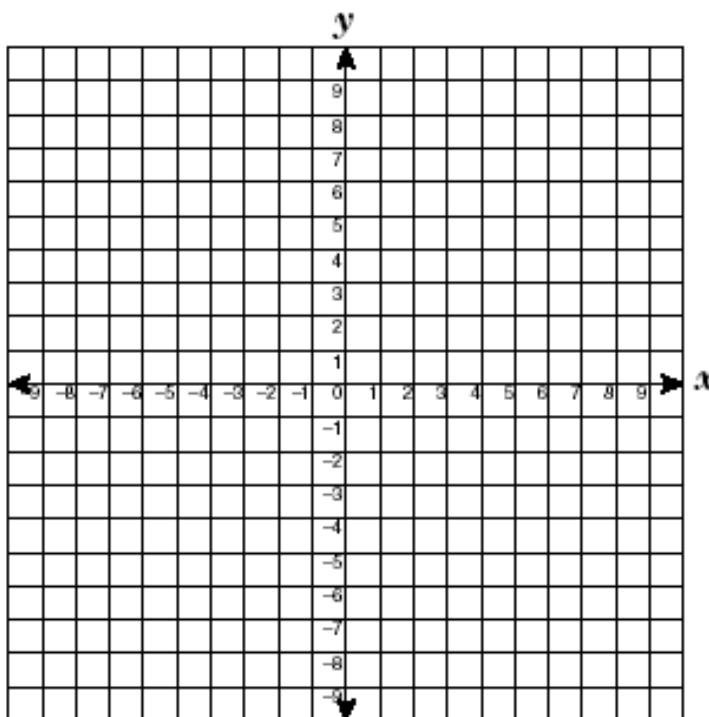

- A 4.61 units
- B 6.52 units
- C 9.22 units
- D 21.25 units

11th Grade 2003

**HIGH SCHOOL Math TEKS FOCUS**  
**Objective Seven**

- 56 Rectangle  $MNPQ$  has diagonals that intersect at point  $X$ .

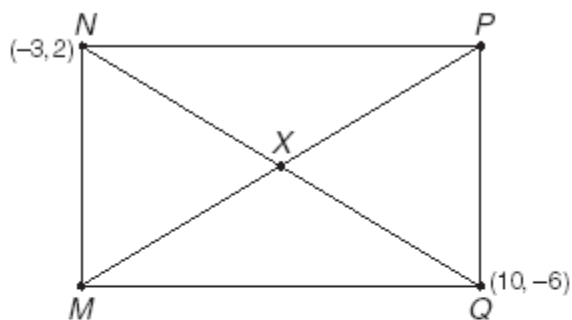

Which of the following represents point  $X$ ?

- F  $(\frac{7}{2}, -2)$
- G  $(\frac{13}{2}, 4)$
- H  $(-\frac{13}{2}, -4)$
- J  $(-\frac{7}{2}, 2)$

11th Grade 2004

**Geometry (e2D)**

*Analyze the characteristics of three-dimensional figures and their component parts*

- 14 How many faces, edges, and vertices does a square pyramid have?
- F 4 faces, 6 edges, and 4 vertices
  - G 5 faces, 6 edges, and 6 vertices
  - H 5 faces, 8 edges, and 5 vertices
  - J 6 faces, 12 edges, and 8 vertices

11th Grade 2003

- 24 Which two 3-dimensional figures have the same number of faces?

- F A triangular prism and a square pyramid
- G A triangular prism and a rectangular prism
- H A triangular pyramid and a square pyramid
- J A triangular pyramid and a rectangular prism

11th Grade 2004